

PLAN

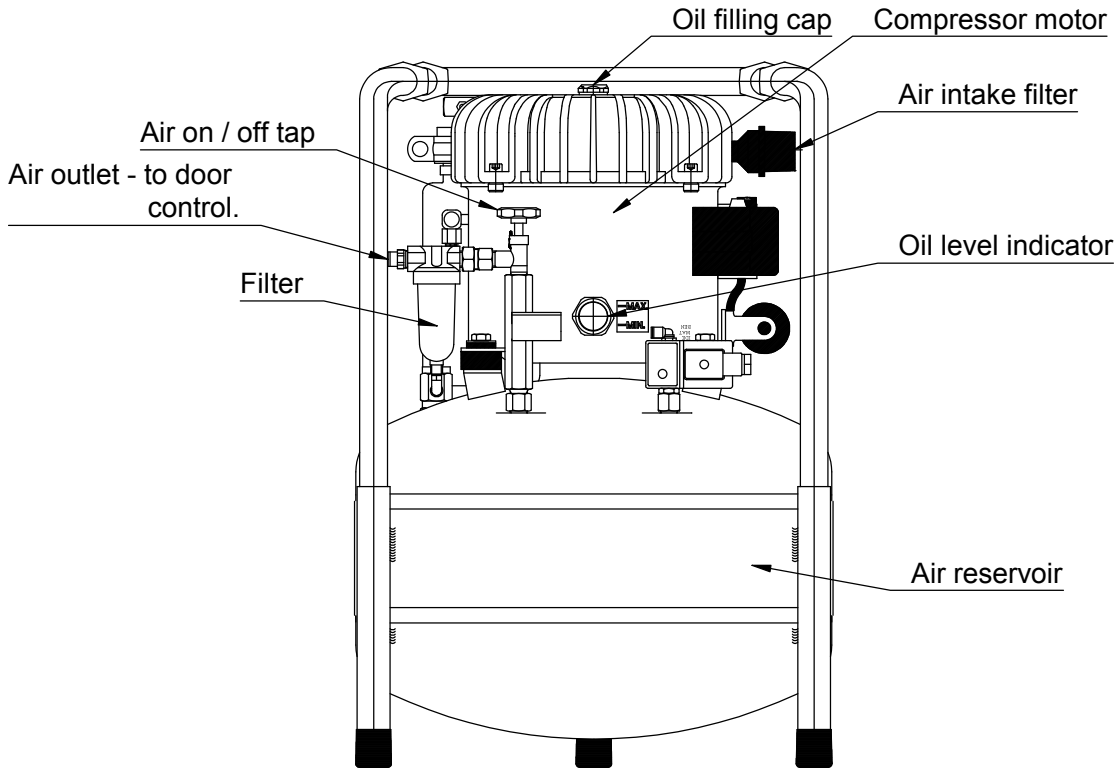

ELEVATION

TECHNICAL DATA:

Voltage	230V 50 Hz
Displacement	50 l/min
Max pressure	8 bar
	120 psi
Power consumption	2.9 amp
Tank size	25 litre
Weight	29 Kg
Dimensions	380 x 380 x 560
Noise level	45 dB at 1m

Revisions

Woodwood (Door Controls) Ltd

Tel: (01245) 490 333 Fax: (01245) 490 111
 email: engineering@woodwood.net web: www.woodwood.net

TITLE
 6-25 Air compressor with 25 litre air reserve tank & auto-drain. Plan, elevation & specification.

SIZE	DRAWN BY:	DWG NO	REV
A4	CW	DS/700/6.25-1	
SCALE	DATE	SHEET	
DNS	29-4-08		