

L180 top pivot

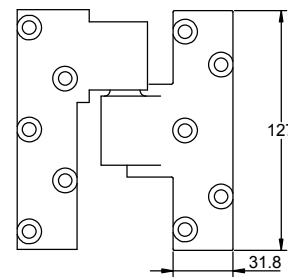

ML19 intermediate pivot

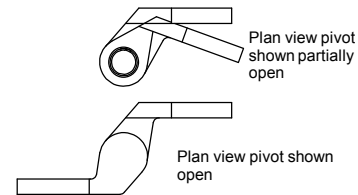
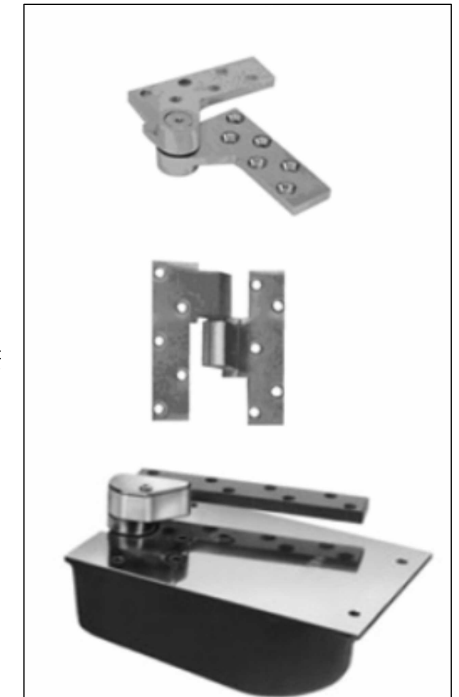

Photograph showing floor spring, intermediate pivot & top pivot.

Product features:

- *Adjustable closing speed
- *Adjustable latch check
- *Adjustable hydraulic backcheck
- *Closer has built in mechanical stop (see notes)
- *Max door weight 680Kg (see notes)

Notes -

Maximum door weight = 680Kg
Max door size = 1219mm wide x 2286* high

*Doors upto 2286 high should use 1 No intermediate pivot, each additional 762mm in height of door warrants another intermediate pivot.

Intermediate pivot ref: ML19
Door stop required at head of door.
Built-in positive dead stop prevents door swinging beyond desired opening 95 degrees standard (85, 90 or 105 degrees available)

Specify FL27 for fire doors

Revisions

Woodwood (Door Controls) Ltd

Tel: (01245) 490 333 Fax: (01245) 490 111
email: engineering@woodwood.net web: www.woodwood.net

TITLE
L27 Single action floor spring for off-set pivoted doors.

SIZE	DRAWN BY:	DWG NO	REV
A4	CW	DS/400/FS-4	
SCALE	DATE	SHEET	
DNS	30-4-09		